

Introduction: The microSpeed™ speedometer supports a variety of application which can support almost any motorcycle. It operates in two basic modes: Digital Bus or Speed Sensor. The Digital Bus mode supports all 2004 or later Harley Davidson Motorcycles and connects to the digital bus signal of the motorcycle. The Speed Sensor mode supports any motorcycle which uses an electronic speed sensor either in the transmission or front wheel. Before beginning installation, please review the entire Installation Instruction and User guide documents to best understand how the microSpeed™ supports your application. Do not attempt to install the microSpeed™ speedometer unless you are comfortable with and understand the procedures. **Speedway Instruments is not responsible for damage to your motorcycle or the speedometer because of improper installation.**

microSpeed™ Wire Color	Description
Red	+12V Power Input (Connect to Accessory Power)
Black	Ground
White	Signal Input (Digital Bus or Speed Sensor Signal)
Blue	+5V output power (Supply Power to Speed Sensor)



Figure 1: Placement option

Placement: Determine the best placement of the microSpeed™ speedometer for your application. This could be on the top clamp, gas tank, or riser. Make sure that you will be able to reach and touch the screen in order to operate the different modes and reset the trip meters. Once you have determine the location, determine the path for the wires. Since wires exit the back of the casing on lower left side you may want to drill a hole big enough to fit wires. Make sure to protect wires from sharp edges! Alternatively, you could mount the speedometer slightly overhanging the surface and route wires in front of the mounting surface. Clean the surface and mount the speedometer using the VHB tape provided. Press and hold firmly in place for at least 10 seconds.

Digital Bus Installation: If your bike is a 2004 or Later Harley Davidson motorcycle the best method for installation is to connect the microSpeed™ speedometer to the digital bus signal. This signal carries all information, including speed, rpm, and distance, from the electronic control module to the instruments. If you do not have a 2004 or Later Harley Davidson motorcycle skip to the Speed Sensor Installation section. You will not need the Blue wire of the microSpeed™ speedometer. It may be cut short, but make sure that the end is properly protected so that it will not accidentally short to metal on the motorcycle. Locate motorcycle wires and determine connection points. The wires are located in the wire bundle that was connected to the existing speedometer.

H.D. Wire color codes (2004-2008)	H.D. Wire color codes (2008+)	Description
LightGreen/Violet	LightGreen/Violet	Digital Bus Signal
Black	Black/Green	Ground
Orange/White	Orange/White	+12V Accessory Power

Note: If you are removing an existing speedometer, before you remove it, record the odometer setting so that you may program the microSpeed™ speedometer with existing mileage. It will also be possible to use the existing wire harness connector if desired.

Procedure:

1. Cut wires and techflex to proper lengths.
2. Connect speedometer wires to proper signal wires as shown in above tables. Use either butt connectors provided or customer provided connectors.
3. Proceed to Setup section below.

Speed Sensor Installation: The microSpeed™ speedometer can be used with either +12V or +5V hall effect electronic sensors located in transmission. Sensor is not include. If your sensor operates on +5V DC wire speedometer to sensor and power as shown in Figure 2 below. Please note that color of wires from the sensor may vary, check sensor documentation for proper signal connections. For +12V sensor you will not need the Blue wire of the microSpeed™ speedometer. It may be cut short, but make sure that the end is properly protected so that it will not accidentally short to metal on the motorcycle. Use Figure 3 below for wiring a +12V sensor.

Procedure:

1. Locate wires and determine connection points. Cut wires and techflex to proper lengths.
2. Connect speedometer wires to proper signal wires as shown in above tables. Use either butt connectors provided or customer supplied connectors.
3. Proceed to Setup Section below.

Setup microSpeed™ Speedometer:

1. Before proceeding review User Guide document for detailed instructions on following procedure.
2. Turn on power to speedometer, display should read “odo”
3. Set initial odometer value
4. Turn off power for 2 seconds; then turn power on again
5. Display should read “F 0”
6. Enter Configuration and Calibration and set speedometer to proper operating mode.
 - a. Harley English
 - b. Harley Metric
 - c. Standard speed sensor English
 - d. Standard speed sensor Metric
7. Set Fuel miles per tank
8. Set Oil change interval
9. Set Speed adjustment
10. Confirm.
11. Test speed is reporting properly and adjust is necessary.

Ride and Enjoy!

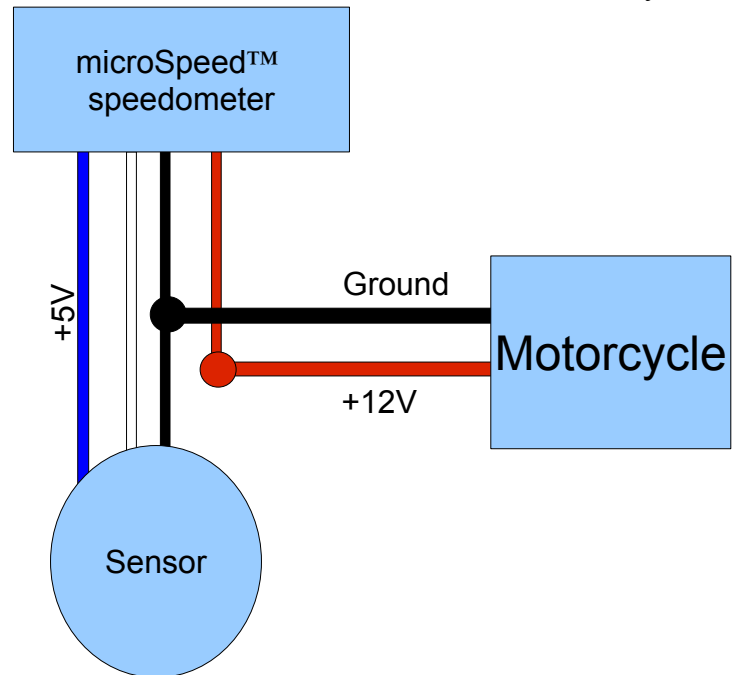

Figure 2: +5V Sensor connections

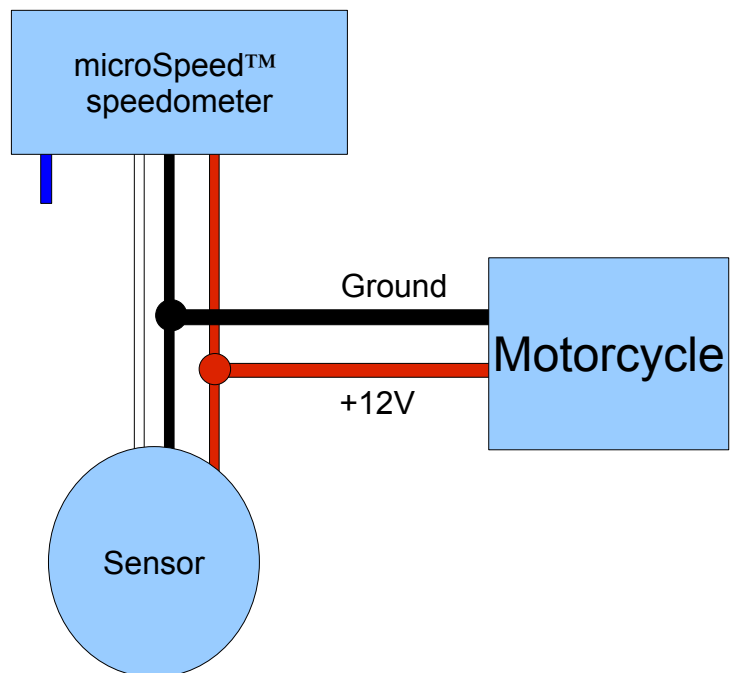

Figure 3: +12V Sensor Connection